

# Exoskeletons in Industry – Designs and their Potential

Konrad S. Stadler

konrad.stadler@zhaw.ch

Daniel Scherly

daniel.scherly@zhaw.ch

School of Engineering, Institute of Mechatronic Systems, Zurich  
University of Applied Science, Switzerland

## Abstract

The main goals for exoskeletons in an industrial setting is summarised. By using two design examples of arm exoskeletons to support workers in manual handling tasks, the potentials for the near future are explained.

## 1 Background

In industry, workers are often subjected to repeated lifting activities where the potential for long-term back injury is significant. Physical stressors during work are associated with an increased risk of lower back pain [1]. In these cases, a low cost, lightweight exoskeleton would benefit the worker, the company, and society in general – most notably improved quality of life due to reduced long-term negative health effects from manual labour in the workplace, reduced medical costs, lost working time, as well as allowing the company to increase flexibility and avoid investment in expensive automation. With fewer musculoskeletal issues, workers are more flexible for different tasks, companies can better adjust to changes in workflow and society bears a lesser burden.

Lumbar spine disorders, such as lower back pain, are frequent in the general population. Their lifetime prevalence is estimated as high as 65-80% [2, 3]. Approximately 44 million EU workers are affected by musculoskeletal conditions resulting in annual costs of more than 240 billion Euro to the European economy [4]. The majority of musculoskeletal problems relate to lower back pain and the major source of back pain is muscle or tendon strain, however there are other causes such as disk herniation and vertebral end plate fracture [5].

According to European Council directive (90/269/EEC), employers are obligated to take appropriate measures to avoid the need for manual handling. Manipulators for manual handling tasks often are available on shop floors, however it is common for companies to have difficulties enforcing the use of these manipulators for light loads and for frequent manipulations. This is due to the fact that the actual load is still manageable for the

worker and using the manipulator slows down the task considerably. Therefore, finding new solutions which support the worker without slowing them down are essential.

Lifting activities are not the only contributor to lower back pain and injury cases. Research has also found that work tasks involving static postures, where the worker is required to maintain trunk flexion over longer periods, increases the risk of back injury with increased exposure [6].

Figure 1a shows the anatomical side view of the lower back. The major muscles (*erector spinae*) of the back are located around the vertebrae and contract to provide the force required to hold the upper body at the desired posture. During bending, the upper body applies a torque around the hips due to gravity, clockwise in Figure 1b. The diagram illustrates the process whereby the muscles located along the spine, shown in red, compensate for the upper body weight. The muscles are similar in principle to weights on a balance beam, whereby the closer the mass is to the pivot point, the greater the mass must be to compensate that on the other side. Due to the muscle's proximity to the axis of rotation, the load they exert on the spine is significantly higher than the lifted load itself. For example, if we assume some approximate human body dimensions during a full horizontal bending motion as shown, the resulting torque is that of the centre of mass of the upper body, approx. 40 kg, applied at a distance of 30 cm from the hips, equating to around 120 Nm. Assuming the distance between the spine and the lower back muscle is around 4 cm, the back muscle must exert a moment of 120 Nm at a distance of 4 cm to the spine, resulting in compression forces of approximately 3000 N + 400 N. Even though carrying an exoskeleton adds mass to a worker, the centre of load of the upper body will be moved closer to the pivot and therefore the compression forces exerted by the lower back muscles can be reduced significantly (Figure 1c).

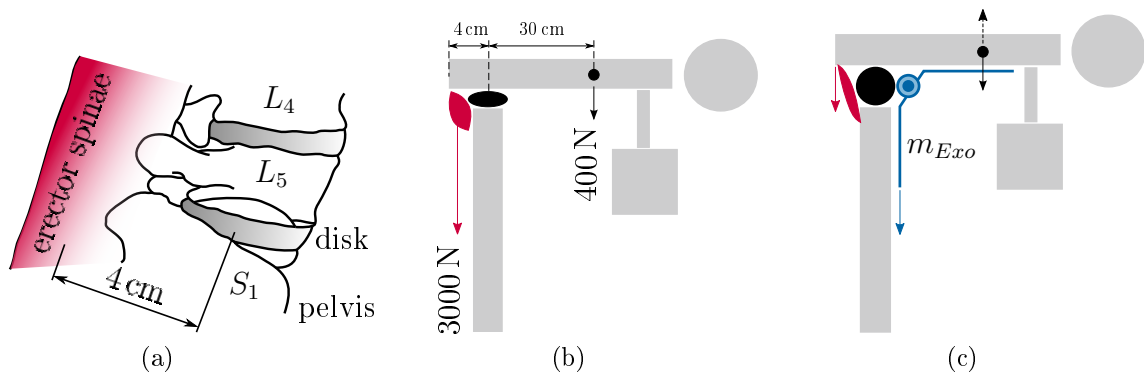

Figure 1: (a) Anatomical side view of the L5/S1 vertebrae. (b) Forces acting on the lower back during simplified bending when the weight of the upper body is approximately 40 kg. (c) Forces acting on the lower back during simplified bending when using an exoskeleton.

There are many methods to assess risks for lifting and bending tasks. A common metric used to determine safe limits for manual handling of loads in various tasks was developed by NIOSH<sup>1</sup> and resulted in the lifting index formula. The recommended weight limit is a combination of many factors, such as the object weight, vertical lifting distance,

<sup>1</sup>The National Institute for Occupational Health and Safety. [www.cdc.gov/niosh](http://www.cdc.gov/niosh)

horizontal location of the object relative to the body, angle of rotation, duration, frequency and some others. NIOSH uses a maximum safe compressive force on the spinal discs of 3.4 kN [7]. In arriving at this estimate, NIOSH reviewed data from cross-sectional field studies and used biomechanical models, although strength estimates vary widely between studies. Some sources claim the NIOSH estimate is conservative after cadaver tests yielded results in the range 4.4-10 kN [8, 9, 10]. However, these values are a maximum, and actual compressive forces should be kept lower to avoid injury. Even without lifting heavy loads, frequent bending and maintaining postures over longer periods increases the risk of injury significantly. The aim of an exoskeleton, therefore, should be to reduce the compression forces in the spinal discs and vertebrae when leaning or lifting loads.

In industry there are many other tasks where exoskeletons may be of significant support for the workers on the shop floor. Examples are handling tools over long periods, overhead work or handling of goods with outstretched arms. Similarly, these activities increase the risk of shoulder injuries for which arm exoskeletons are developed. Within our projects we have developed both trunk and arm exoskeletons to reduce the compression forces in the lower back and in the shoulders, respectively.

## 2 Main Exoskeletons for Industrial Use

The field of exoskeleton research has exploded in the last few years, there have been many studies performed and many are still in progress. Some exoskeletons are in active development however few are available for sale which target the industrial use case. Exoskeletons can broadly be categorised into a few groups, those intended for research, military, industrial, and medical. Some of the most current relevant exoskeletons are briefly explained below.

SuitX MAX<sup>2</sup>: This modular passive exoskeleton is comprised of three modules for the knees, back, and shoulders and can be used independently or in any combination. It aims to reduce muscle activity in the major muscle groups associated with lifting, bending, squatting and overhead work. For example, the BackX module weighs 2 kg and it was shown that it reduces muscle activity in four muscle groups of the back by an average of 60%. The load of the upper body is transmitted via a chest support to the thighs.

Laevo<sup>3</sup>: A wearable passive chest and back support exoskeleton which reduces muscle activity in the back by up to 40%. The principle of operation is similar to the BackX from SuitX, in that the load is transmitted from a chest support to the thighs via a passive spring element. The wearer cannot sit while wearing the Laevo but it is light and easy to don and doff.

Fortis<sup>4</sup>: A passive exoskeleton for use in industrial environments developed by Lockheed Martin. It transfers loads through the exoskeleton to the ground in the standing or kneeling position, allowing the operator to use heavy equipment. This concept is different

---

<sup>2</sup>[www.suitx.com](http://www.suitx.com)

<sup>3</sup>[en.laevo.nl](http://en.laevo.nl)

<sup>4</sup>[www.lockheedmartin.com/us/products/exoskeleton.html](http://www.lockheedmartin.com/us/products/exoskeleton.html)

from the others mentioned as the load is not transferred from the torso to the thighs, instead the waist belt holds the weight of the tool and transfers the load via a frame directly to the ground. A significant drawback of this system is that it uses counterweights to balance the tool weight. Counterweights add mass to the exoskeleton and even though the user does not carry the load, the additional load must be accelerated when moving making movement slower, clumsier and increasing the energy expended. Minimal weight of the exoskeleton is therefore required.

Chairless chair<sup>5</sup>: This is a wearable device that allows the worker to partially sit while at their workplace without a traditional chair. It is included here since it is available for purchase, is simple and unpowered. So far they have gained significant traction in industry especially the automotive sector. It goes to show that worker assist technologies are viable and sought after on the market.

Robo-Mate<sup>6</sup>: In our EU funded project, which was completed at the end of 2016, three “modules”, one trunk and two upper body exoskeletons were developed. The trunk module provides a torque at the hip using motors to support the upper body during bending and lifting. The final prototype provided a measurable reduction in lower back muscle activity when used, however was too heavy for prolonged use. The key take-away from development here showed that the principle of lower back support is sound and through industry contacts we learned that there is definitely a market for it, however the implementation must become much lighter and less obtrusive.

A key factor in determining the usefulness of an exoskeleton is the change in metabolic rate or muscle activity when wearing it. Other critical aspects are size and weight, complexity, price and availability, functionality and adjustability. An important aspect to note is that there are no viable powered mobile exoskeletons available which are intended for industrial applications and can be worn comfortably for a full work day. Powered exoskeletons for medical applications exist, but assistance exoskeletons for healthy people are much less common. The motors, batteries, electronics and support structures are currently just too heavy to be viable as a product. The human body is an extremely efficient machine, and improving its efficiency or augmenting its power in any significant way is a highly challenging task.

### 3 Mechatronic Designs – Examples

The design of our exoskeletons was driven by two main considerations (see [11] for details). The first is to keep the complexity of the exoskeleton at a minimum. Industry has only recently begun to adopt collaborative robots and significant efforts are underway to develop standards to define the safe use of such concepts [12]. Powered exoskeletons are not just collaborative robots but wearable robots. Even though a standard exists [13] for personal care robots – which includes exoskeletons – it is still unclear if industry will adopt this standard. Keeping the complexity of an exoskeleton at a minimum reduces the

---

<sup>5</sup>[www.noonee.com](http://www.noonee.com)

<sup>6</sup>[www.robomate.eu](http://www.robomate.eu)

risks of an incident and therefore increases the acceptance with all stake holders. From this perspective it is not surprising that the only commercially available exoskeletons are all passive (e.g. spring powered) devices. A second aspect considered is that not all tasks can be handled by the same exoskeleton, as some simple tasks may only need the user's body weight to be compensated. Others may need a sophisticated intention detection scheme to support the worker. Today's available actuators are by no means lightweight. Every actuated degree of freedom adds significant weight to the body. Moving requires accelerating the additional weight as well the worker's own body weight. Due to this, an exoskeleton supporting all of the body's degrees of freedom is not feasible. Exoskeletons need to be designed to match specific industrially relevant tasks. In the following chapters, two exoskeletons are described. Both are designed to support the worker's arm movement and to reduce the compression forces in the shoulder. However, the industrial tasks driving the designs are different.

Within the Robo-Mate project a general requirement was to support additional loads up to 7.5kg per hand and that the hands and fingers are unsupported, i.e. the objects are carried in the hands of the worker. No grippers or other support mechanisms should be used.

### 3.1 Passive Parallelogram Arm

The goal of the passive parallelogram arm module (Figure 2) is to provide an energy efficient and robust tool **to support a non varying load**. The main usage is to handle a tool continuously, for example an angle grinder, or to compensate the user's own arm weight in awkward and strenuous postural positions.

A spring is connected to a four-bar linkage [14] instead of spanning the entire diagonal of the parallelogram. The four-bar linkage is denoted  $a$ ,  $b$ ,  $c$  and  $r$  in the diagram of Figure 2a or are the red coloured parts in the picture of Figure 2b. The resulting spring forces in the parallelogram structures provide a gravity-counteracting lifting force  $F_z$ . Choosing appropriate lengths  $a$ ,  $b$  and  $c$  and the angle  $\xi$  the lifting force  $F_z$  is nearly constant independent of the angle  $\phi$ . By changing length  $r$  the lifting force is changed and can be therefore used to adjust it according to the user's needs. Details on the design can be found in [15].

Two parallelograms are connected in series to provide an unrestricted arm movement. Lateral movements are unsupported and unhindered in the required reach space. The final prototype was designed by taking into account the maximum required movements ranges, a total load of 120 N (this includes the maximum supported load of 75 N with an additional 45 N to compensate the worker's arm). The dimensions of the parallelogram were derived by optimisation where the following cost function was used.

$$\min_{a,b,c,\xi} [\max(F_z(\phi|r)) - \min(F_z(\phi|r))] + |120 \text{ N} - F_z(\phi|r = 45 \text{ mm})| \quad (1)$$

The notation  $F_z(\phi|r)$  means the function  $F_z(\phi)$  at a given value  $r$ . The first difference

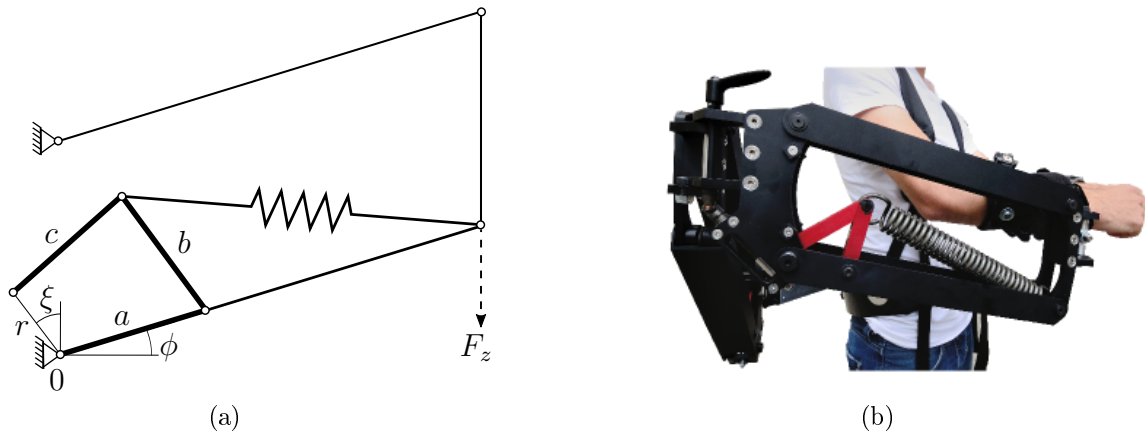

Figure 2: (a) Sketch of the main dimensions of the passive arm exoskeleton. (b) Picture of the passive arm prototype.

assures that the lifting force is approximately constant over the whole vertical range. The second difference is a penalty term, which makes sure that the geometrical lengths are appropriate to reach the maximal required lifting force. In Figure 3, the angle  $\phi$  – which defines the arm location and the shape of the parallelogram – versus the lifting force  $F_z$  is shown. Each line represents a different value of length  $r$ . For small values of  $r$  a horizontal line is achieved and for larger values of  $r$  the difference is about  $\pm 2\%$  of the total lifting

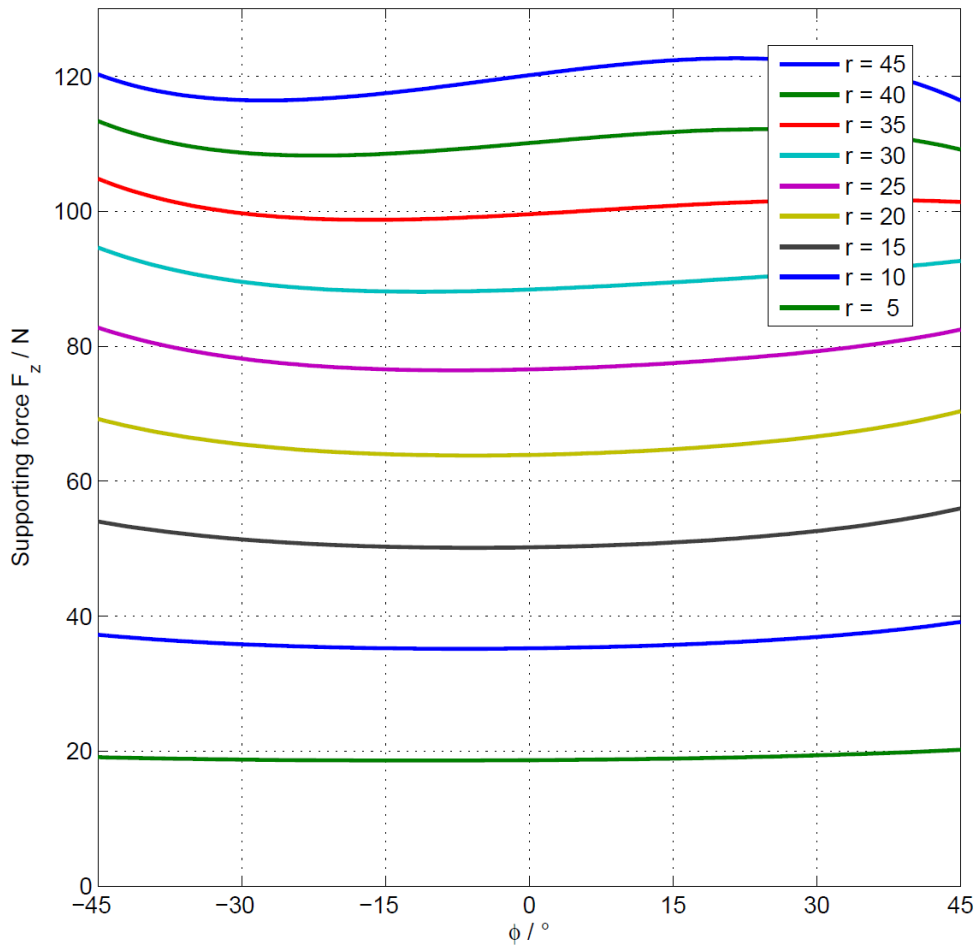

Figure 3: Iso-elastic characteristics for different supporting forces over the vertical movement range of the arm.

force. This indicates that only little energy is required to move the arm to any location in the whole movement range. The prototype was manufactured from aluminium and weighs approximately 3.7kg.

A significant weight reduction is possible by using different materials and changing the design. For example the front parallelogram could be easily reduced to a triangle. We estimate that a total weight below 2kg is easily possible. This exoskeleton is ideal for rough environments (for example handling a grinding tool) as no sensors or electrical actuators are used and therefore little maintenance is required.

### 3.2 Active Parallelogram Arm

Moving away from tasks where constant loads are manipulated to those where the loads change continuously, constant support is not adequate. These tasks are typically found in logistics or in assembly lines. Goods and tools are moved and manipulated (pick and place). To support these tasks, it is important to dynamically switch the supporting force of the exoskeleton arm. For this purpose, the active parallelogram module (Figure 4) was developed, based on the structure of the passive arm (Fig. 2a). However, the springs have been replaced by a single wire passing through both segments. In the front parallelogram, two sides (upper and front) were removed to reduce weight (reducing essentially the front parallelogram segment to a triangle). A single motor (brushless motor EC-i40 from *maxon motors* in connection with a worm gear and spindle) at the trunk end of the module provides the load supporting force. For pick and place activities the lifting force is dynamically adapted based on pressure sensor inputs. These are sewn into a glove and are placed in the palm of the worker. The rear parallelogram and the front triangle are connected in series to provide an unrestricted arm movement corresponding to the passive version. The final prototype was manufactured from aluminium and weighs approximately 2.3 kg, which includes the motor, but no battery pack or other electrical components.

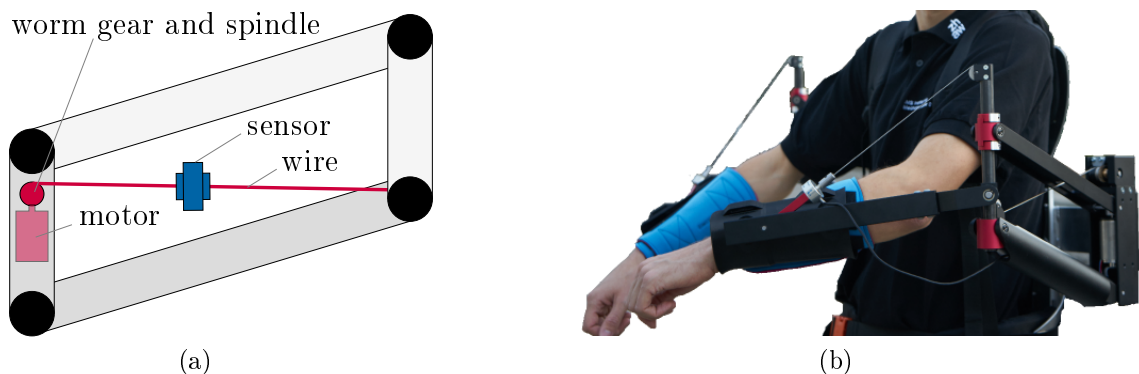

Figure 4: (a) Sketch of the active parallelogram arm exoskeleton. (b) Picture of the active parallelogram arm prototype.

## 4 Results and Conclusion

The passive and the active arm have similar weights. However, the active arm was developed after the passive arm and several measures were taken to reduce the weight, which could be considered also for the passive arm. The passive arm has a more restricted use, but is far more robust than the active arm.

Neither arm is anthropomorphic, i.e. they do not follow the human limbs closely. Anthropomorphic arm exoskeletons would require a much smaller space around the worker, which is beneficial in constraint environments. On the other hand, to provide a force counteracting gravity at the hand of the worker at least two motors powering the elbow and the shoulder need to be used. This essentially doubles the amount of sensors used, the motors used and the battery power required. Hence, the weight of the exoskeleton would be significantly higher, which is undesired.

The two examples show that by analysing the tasks carefully, the exoskeleton design can vary significantly. Despite that the passive arm is not weight optimised, it is much closer to a commercial product due to the simplicity of the design. The active arm needs considerable further development with respect to safety (e.g. redundancy of sensors) to make the system safe for industrial use. Furthermore, the robustness of electrical parts in a rough environment needs to be considered.

Industries in Europe are eager to find new solutions for their manufacturing and assembly lines, as health costs are ever increasing. For regulation, certification and acceptance issues, passive devices have a clear advantage in the near future.

## Acknowledgements

This project and the research leading to these results have received funding from the European Union's Seventh Framework Programme for research, technological development and demonstration under grant agreement N<sup>o</sup> 608979.

## References

- [1] Arun Garg et al. The NIOSH Lifting Equation and Low-Back Pain, Part 1: Association With Low-Back Pain in the BackWorks Prospective Cohort Study. *Human Factors*, 56(1):6–28, February 2014.
- [2] Richard A. Deyo and James N. Weinstein. Low Back Pain. *New England Journal of Medicine*, 344(5):363–370, February 2001.
- [3] Judith I Kuiper et al. Assessing the work-relatedness of nonspecific low-back pain. *Scandinavian Journal of Work, Environment & Health*, (3):237–243, 2005.
- [4] Stephan Bevan. The impact of back pain on sickness absence in Europe. June 2012.



- [5] Joseph Hamill and Kathleen M. Knutzen. *Biomechanical Basis of Human Movement*. Lippincott Williams & Wilkins, October 2006.
- [6] L. Punnett, L. J. Fine, W. M. Keyserling, G. D. Herrin, and D. B. Chaffin. Back disorders and nonneutral trunk postures of automobile assembly workers. *Scandinavian Journal of Work, Environment & Health*, 17(5):337–346, October 1991.
- [7] Thomas R. Waters, Vern Putz-Anderson, Arun Garg, and Lawrence J. Fine. Revised NIOSH equation for the design and evaluation of manual lifting tasks. *Ergonomics*, 36(7):749–776, 1993.
- [8] R. W. Porter, M. A. Adams, and W. C. Hutton. Physical activity and the strength of the lumbar spine. *Spine*, 14(2):201–203, February 1989.
- [9] Martin Biggemann, Dietrich Hilweg, and Paul Brinckmann. Prediction of the compressive strength of vertebral bodies of the lumbar spine by quantitative computed tomography. *Skeletal Radiology*, 17(4):264–269, June 1988.
- [10] M. Jaeger and A. Luttmann. Biomechanical analysis and assessment of lumbar stress during load lifting using a dynamic 19-segment human model. *Ergonomics*, 32(1):93–112, January 1989.
- [11] Konrad S. Stadler, Ruprecht Altenburger, Emilio Schmidhauser, Daniel Scherly, Jesus Ortiz, Stefano Toxiri, Luis Mateos, and Jawad Masood. *Advances in Cooperative Robotics*, chapter Robo-Mate an Exoskeleton for Industrial Use: Concept and Mechanical Design, pages 806–813. World Scientific, London, 2016.
- [12] ISO/TS 15066:2016 Robots and robotic devices – Collaborative robots, 2016. International Organization for Standardization (ISO).
- [13] ISO 13482:2014 Robots and robotic devices – Safety requirements for personal care robots, 2014. International Organization for Standardization (ISO).
- [14] Neil Sclater and Nicholas P. Chironis. *Mechanisms and mechanical devices sourcebook*. McGraw-Hill, 4th ed edition, 2007.
- [15] Ruprecht Altenburger, Daniel Scherly, and Konrad S. Stadler. Design of a passive, iso-elastic upper limb exoskeleton for gravity compensation. *ROBOMECH Journal*, 3(1), December 2016.